

## Product description:

Butterfly valve, wafer type used for potable water and other neutral liquids

Working temperature from 0°C (no frost) to 80°C

## Standards:

- Designed according to EN593
- Face to face length EN558-1 serie 20
- Flanges connection according to EN1092-2

## Pressure tests:

All valves are individually hydrostatically tested according to BS EN12266-1

- Seal: 1,1 x PN (in bar)
- Body: 1,5 x PN (in bar)

## Corrosion protection:

- RAL 5005 epoxy powder painting
- Applied internally and externally with a minimum layer thickness of 250 µm

## Approvals:

- Certificate PED 014/68/ UE No. 1282, risk category III/model H
- Certificate EUROFINS ACS no.23 ACC NY 257 for use in contact with drinking water

## Characteristics:

1. Butterfly valve, wafer type certificated for potable water
2. Body in ductile iron GGG50
3. Stem in stainless steel SS420
4. Disc in ductile iron GGG50 and gasket of EPDM
5. PN10/16 up to DN150 and both options ≥ DN200
6. Handwheel actuated up to DN200 and with gearbox for DN≥250



**3.1**

**CE**



## DN40-DN350

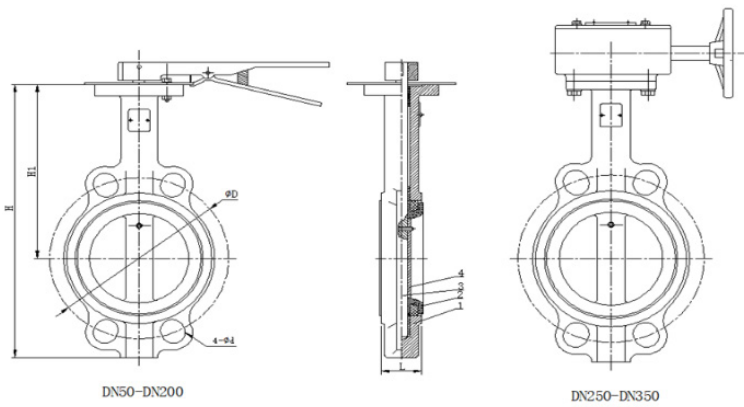

No.	Parts	Materials
1	Body	GGG50
2	Disc	GGG50
3	Stem	SS420
4	Gaskets	EPDM

DN	L	H	H1	φD	4-φd	Screws	φD	4-φd	Screws	ISO PAD	Weight (kg)
				PN 10			PN16				
40	33	177	110	110	4-φ19	4-M16	110	4-φ19	4-M16	F05	1.71
50	43	241	161	125	4-φ19	4-M16	125	4-φ19	4-M16	F05	2.25
65	46	264	175	145	4-φ19	4-M16	145	4-φ19	4-M16	F05	2.59
80	46	276	181	160	4-φ19	8-M16	160	4-φ19	8-M16	F05	3.23
100	52	314	200	180	4-φ19	8-M16	180	4-φ19	8-M16	F07	4.34
125	56	340	213	210	4-φ19	8-M16	210	4-φ19	8-M16	F07	5.69
150	56	365	226	240	4-φ23	8-M20	240	4-φ23	8-M20	F07	7
200	60	440	260	295	4-φ23	8-M20	295	4-φ23	12-M20	F10	10.4
250	68	500	292	350	4-φ23	12-M20	355	4-φ28	12-M24	F10	21
300	78	584	337	400	4-φ23	12-M20	410	4-φ28	12-M24	F10	29
350	78	635	368	460	4-φ23	16-M20	470	4-φ28	16-M24	F10	36

## DN400-DN1200

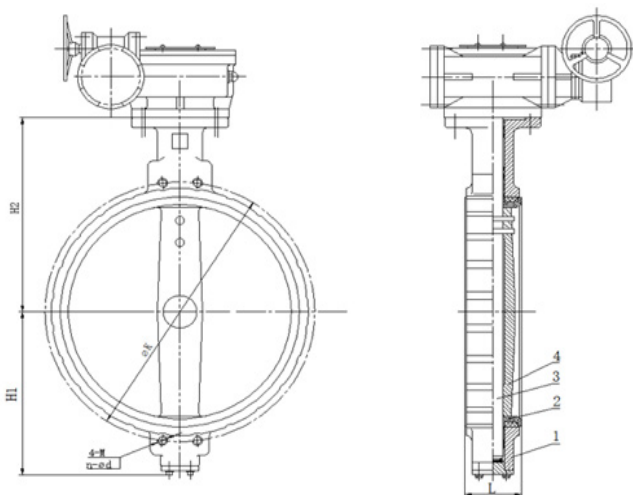

No.	Parts	Materials
1	Body	GGG50
2	Disc	GGG50
3	Stem	SS420
4	Gasket	EPDM

DN	L	H1	H2	φK	4-φd PN10	Screws	φK	4-φd PN16	Weight(kg)
400	900	580	515	525	480	16-27	16-30	28	68
450	109	318	422	565	4-φ28	/	585	4-φ31	78
500	135	349	480	620	4-φ28	/	650	4-φ34	103
600	156	410	562	725	20-φ31	/	770	20-φ37	170
700	169	527	629	840	/	4-M27	840	/	260
800	195	601	666	950	/	4-M30	950	/	330
900	211	653	722	1050	/	4-M30	1050	/	450
1000	229	718	800	1160	/	4-M33	1170	/	540
1200	286	864	941	1380	/	4-M36	1390	/	700