

Product description:

Flanged resilient seated gate valve used for potable water and other neutral liquids

Working temperature from 0°C (no frost) to 80 °C

Standards:

- Designed according to DIN3352
- Face to face length according to DIN3202 F5
- Flanges connection according to BS1092-2

Pressure tests:

All valves are individually hydrostatically tested according to BS EN12266-1 and EN1074

- Seal: 1,1 x PN (in bar)
- Body: 1,5 x PN (in bar)

Corrosion protection:

- RAL 5005 epoxy powder painting
- Applied internally and externally with a minimum layer thickness of 250 µm
- Fixing elements protected from external aggressions with wax coating

Approvals:

- Certificate PED-H 2020-T029, category III / model H
- Certificate WRAS no. 2001315

Characteristics:

- Resilient seated gate valve certified for drinking water
- Body and bonnet in ductile iron GGG50
- SS420 stainless steel stem
- GGG50 ductile iron wedge covered with a thick layer of EPDM elastomer
- Ribs on the outer face of the wedge to facilitate its guidance on the body
- A2-70 stainless steel body/bonnet bolts, protected by wax coating
- PN10/16 up to DN150 and both options for sizes \geq DN200
- Actuated with a handwheel up to DN600 and with gearbox for $\text{DN} \geq 700$

**3.1**

DN 40 - DN 600

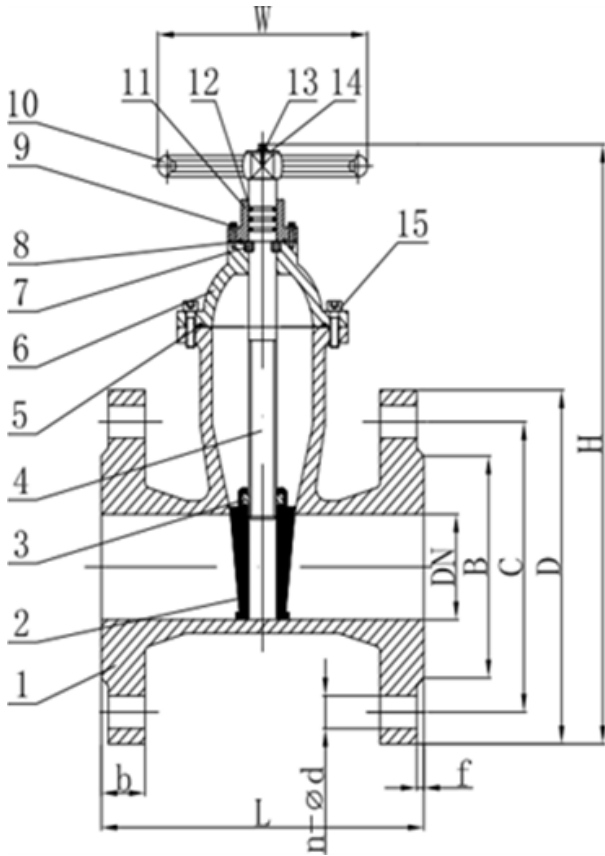

No.	Parts	Materials
1	Body	GGG50
2	Wedge	GGG50+EPDM
3	Stem nut	Brass
4	Stem	SS420
5	Gasket	EPDM
6	Bonnet	GGG50
7	Locating O-ring	Brass
8	O-ring	EPDM
9	Bolt	A2-70
10	Handwheel	Painted carbon steel
11	Gland	GGG50/Brass
12	O-ring	EPDM
13	Nut	A2-70
14	Washer	A2-70
15	Suruburi	A2-70

DN	L		D		C		B		n-d		b		f	Greutate
	F5	PN10	PN16	PN10	PN16	PN10	PN16	PN10	PN16	PN10	PN16			
40	240	150	150	110	110	84	84	4-19	4-19	19	19	3	11	
50	250	165	165	125	125	99	99	4-19	4-19	19	19	3	11	
65	270	185	185	145	145	118	118	4-19	4-19	19	19	3	13	
80	280	200	200	160	160	132	132	4-19	8-19	19	19	3	16	
100	300	220	220	180	180	154	154	8-19	8-19	19	19	3	20	
125	325	250	250	210	210	184	184	8-19	8-19	19	19	3	29	
150	350	285	285	240	240	211	211	8-23	8-23	19	19	3	39	
200	400	340	340	295	295	266	266	8-23	12-23	20	20	3	58	
250	450	405	405	350	355	319	319	12-23	12-28	22	22	3	86	
300	500	460	460	400	410	370	370	12-23	12-28	24.5	24.5	4	125	
350	550	520	520	460	470	429	429	16-22	16-27	24.5	26.5	4	170	
400	600	580	580	515	525	480	480	16-27	16-30	24.5	28	4	235	
450	650	615	640	565	585	548	548	20-27	20-30	25.5	30	4	335	
500	700	670	715	620	650	582	582	20-27	20-33	26.5	31.5	4	360	
600	800	780	840	725	770	682	682	20-31	20-37	30	36	4	520	

DN 700 - DN 1200

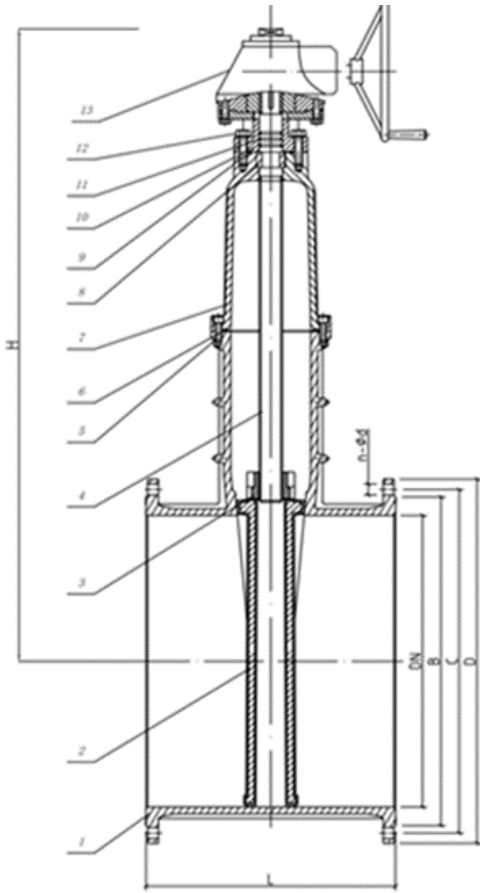

No.	Parts	Materials
1	Body	GGG50
2	Seal	EPDM
3	Stem	SS420
4	Wedge	Ductile iron
5	Wedge nut	Brass
6	Bonnet Gasket	EPDM
7	Nut	A2-70
8	Bonnet	Ductile iron
9	O-ring	EPDM
10	Washer	A2-70
11	Sealing O-ring	Brass
12	Gearbox	Ductile iron

DN	L	D		C		B		n-d		H	Greutate
	F5		PN16	PN10	PN16	PN10	PN16	PN10	PN16	mm	(kg)
700	900	895	910	840	840	794	794	24-31	24-37	1320	950
800	1000	1015	1025	950	950	901	901	24-34	24-40	1490	1300
900	1100	1115	1125	1050	1050	1001	1001	28-34	28-40	1700	1650
1000	1200	1230	1255	1160	1170	1112	1112	28-37	28-43	1875	2600
1200	1400	1455	1485	1380	1390	1328	1328	32-41	32-49	2350	3200